



INSTALLATION INSTRUCTIONS WINCH MOUNTING KIT

Part Number: 70830

Application: Honda Rubicon/Foreman 500

Your safety, and the safety of others, is very important. To help you make informed decisions about safety, we have provided installation and operating instructions and other information on labels and in this guide. This information alerts you to potential hazards that could hurt you or others. It is not possible to warn you about all potential hazards associated with this product, you must use your own good judgment.

CARELESS INSTALLATION AND OPERATION CAN RESULT IN SERIOUS INJURY OR EQUIPMENT DAMAGE. READ AND UNDERSTAND ALL SAFETY PRECAUTIONS AND OPERATING INSTRUCTIONS BEFORE INSTALLING AND OPERATING THIS PRODUCT.

This guide identifies potential hazards and has important safety messages that help you and others avoid personal injury or death. **WARNING** and **CAUTION** are signal words that identify the level of hazard. These signal words mean:

▲WARNING signals a hazard that *could* cause serious injury or death, if you do not follow recommendations. **▲CAUTION** signals a hazard that *may* cause minor to moderate injury, if you do not follow recommendations.

This guide uses **NOTICE** to call attention to important mechanical information, and **Note**: to emphasize general information worthy of special attention.

▲ WARNING

INJURY HAZARD

Failure to observe these instructions could lead to severe injury or death.

- ❑ **Always** use extreme caution when drilling on any vehicle. Make sure that all fuel lines, brake lines, electrical wires, and other objects are not punctured or damaged when / if drilling on the vehicle. Thoroughly inspect the area to be drilled (on both sides of material) prior to drilling, and relocate any objects that may be damaged. Failure to inspect the area to be drilled may result in vehicle damage, electrical shock, fire or personal injury.
- ❑ **Always** wear safety glasses when installing this kit. A drilling operation will cause flying metal chips. Flying chips can cause eye injury.
- ❑ **Always** use extreme caution when cutting and trimming during fitting.
- ❑ **Always** remove jewelry and wear eye protection.
- ❑ **Never** lean over battery while making connections.
- ❑ **Never route electrical cables:**
 - Across any sharp edges.
 - Through or near moving parts.
 - Near parts that become hot.
- ❑ **Always** insulate and protect all exposed wiring and electrical terminals.
- ❑ **Always** install terminal boots as directed in installation instructions.
- ❑ **Always** use appropriate and adequate care in lifting components into place.
- ❑ **Always** insure components will remain secure during installation and operation.
- ❑ **Always** tighten all nuts and bolts securely, per the installation and operation.
- ❑ **Always** perform regular inspections and maintenance on the winch, winch mount and related hardware.
- ❑ **Never** operate this **WARN** product with damaged or missing parts.

⚠ Caution
Moving Parts Entanglement Hazard
Failure to observe these instructions could lead to minor or moderate injury.
<ul style="list-style-type: none"> <input type="checkbox"/> Always take time to fully read and understand the installation and Operations Guide included with this product. <input type="checkbox"/> Never operate this product if you are under 16 years of age. <input type="checkbox"/> Never operate this product when under the influence of drugs, alcohol or medications.
Read installation and operating instructions thoroughly.

Notice
Equipment Damage
<ul style="list-style-type: none"> <input type="checkbox"/> Always refer to the Installation and Specification Guide, supplied in the winch kit, for all wiring schematics and specific details on how to wire this WARN product to your vehicle.
Read installation and operating instructions thoroughly.

Table of Contents

I.	Parts List	3
II.	Tools Required	3
III.	Rubicon/Foreman 500 Installation	3
IV.	Recommended Contactor Location	8
V.	Maintenance/Care	9

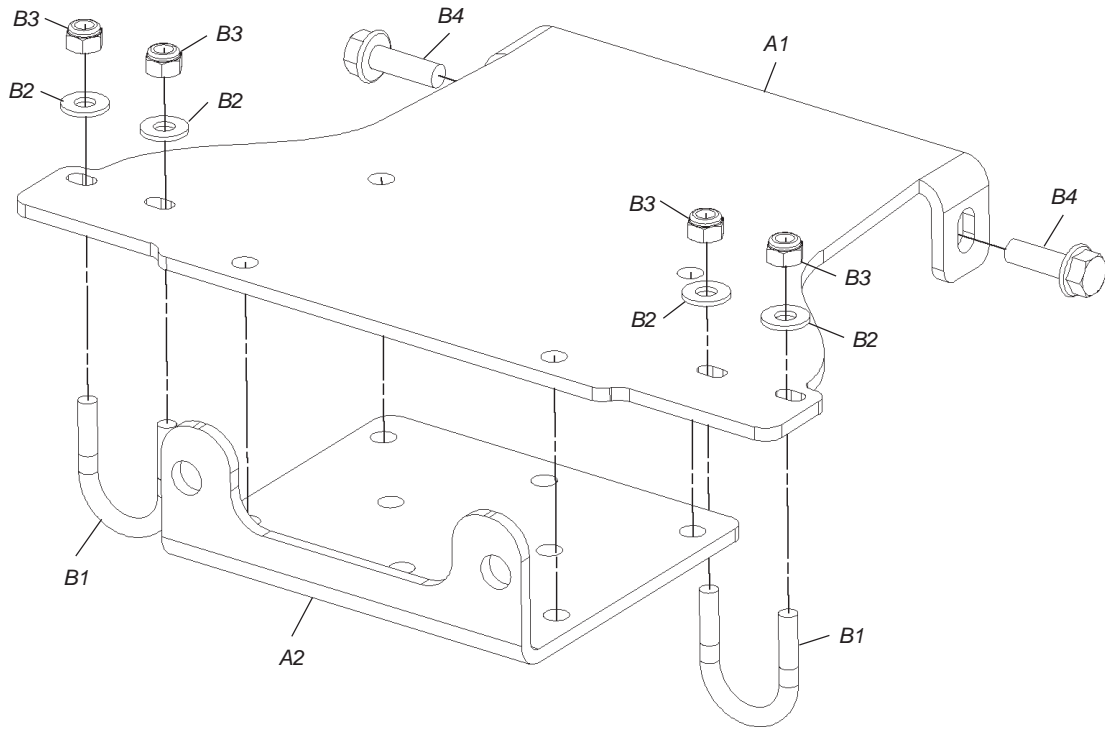

I. Parts List

<u>Ref</u>	<u>Description</u>	<u>Qty</u>
A1	Mounting Plate	1
A2	Roller Fairlead Mounting Bracket (supplied in winch kit)	1
B1	1/4-20 x 1" x 1 3/16" U-bolt	2
B2	1/4" lock washer	4
B3	1/4-20 nut	4
B4	8mm-1.25 x 25mm bolt	2

II. Tools Required

- Ratchet
- Sockets: 10mm, 12mm, 7/16", 1/2", 9/16"
- Wrenches: 1/2", 9/16"
- Drill
- 1/4" drill bit

III. Rubicon/Foreman 500 Installation

1. Begin by removing the front skid plate located on the front of the ATV. Remove the four side 8mm bolts and four bottom 6mm bolts securing the front skid plate, figure 1. Save the fasteners as they will be used later to reinstall the front skid plate.

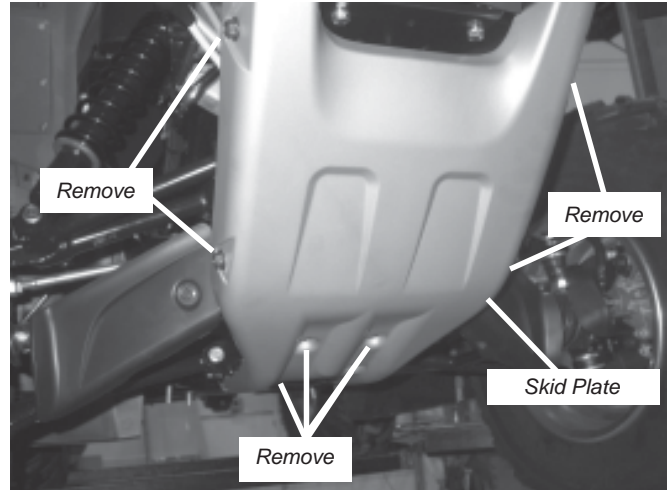

Figure 1 Remove Front Skid Plate

2. Remove the four plastic rivets on each side of the front plastic fascia, figure 2. Use a large screw driver to carefully remove the center rivet. After removing the center rivet, remove the rivet housing. Save the fasteners as they will be used to reinstall the front plastic fascia.

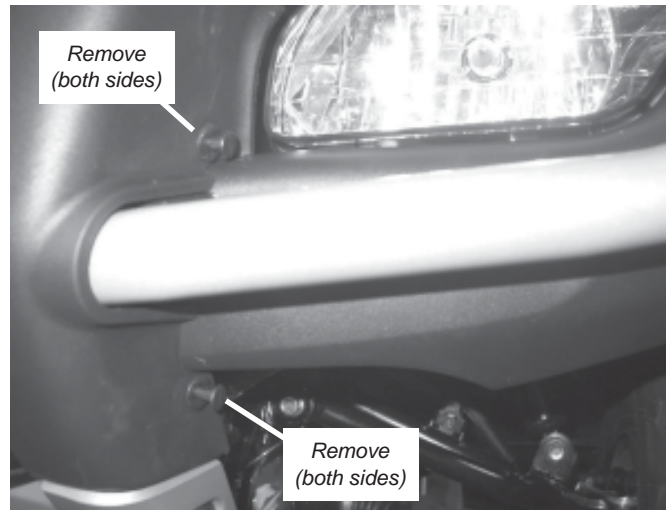

Figure 2 Remove the Four Plastic Rivets

3. Remove the two 6mm bolts that attach the front bumper to the plastic headlight assembly, figure 3. Save the fasteners as they will be used to reinstall the front bumper.

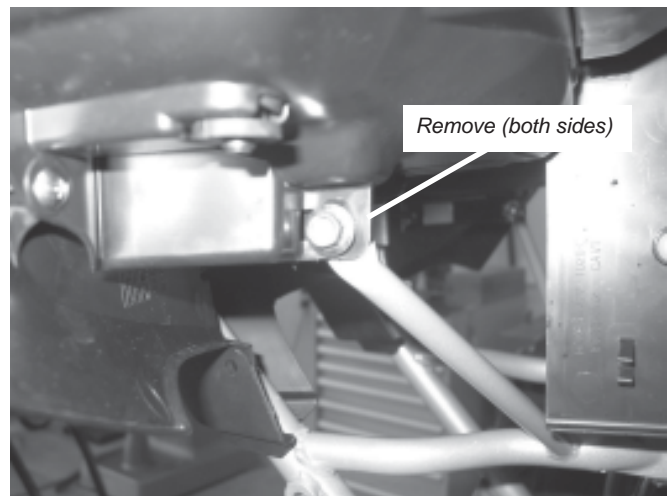

Figure 3 Front Bumper Bolts

4. Remove the two top 8mm bumper bolts that attach the front bumper to the front rack, figure 4. Save the fasteners as they will be used to reinstall the front bumper.

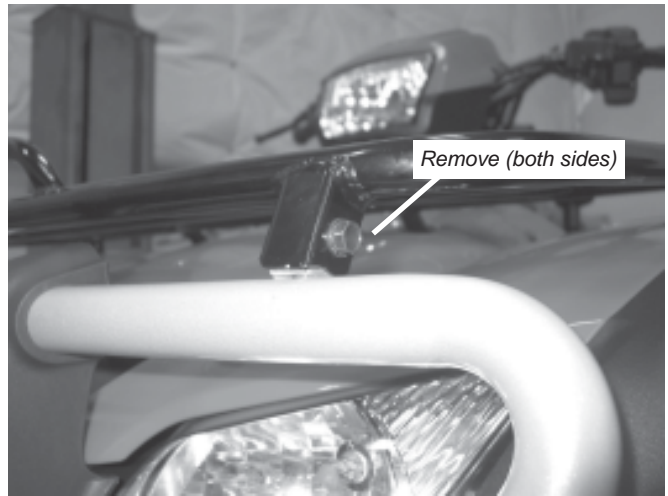

Figure 4 Remove Top Bumper Bolts

5. Remove the two bottom bumper bolts that attach the bumper to the bottom of the vehicle frame, figure 5. Save the fasteners as they will be used to reinstall the front bumper.

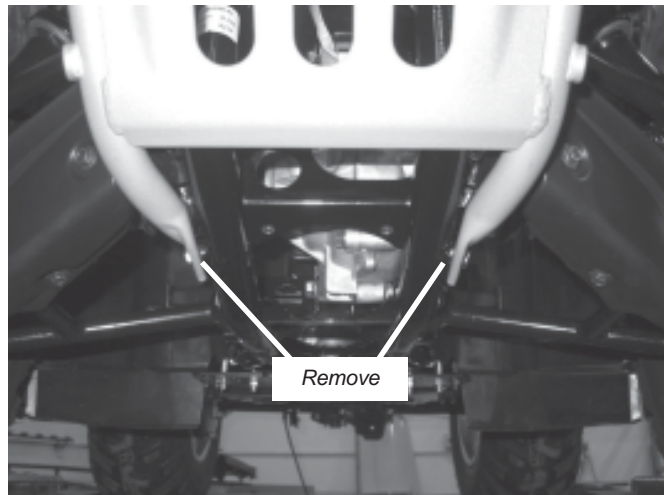

Figure 5 Remove Bottom Bumper Bolts

6. Remove the two middle bumper bolts that attach the bumper to the middle of the vehicle frame, figure 6. Remove the front vehicle bumper at this time.

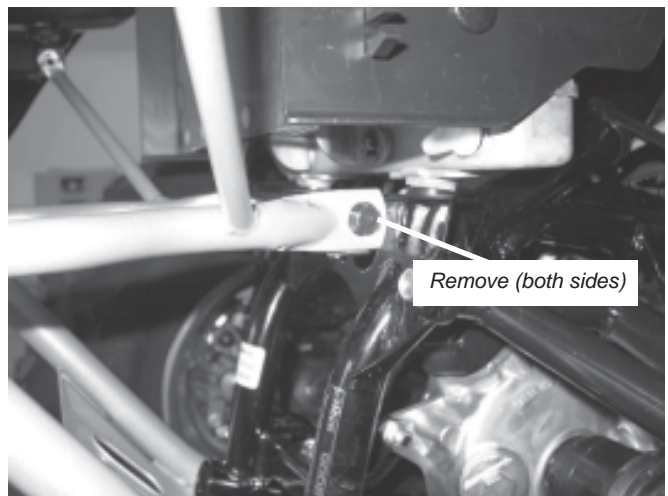

Figure 6 Remove Middle Bumper Bolts

- Attach fairlead to the fairlead mounting bracket (A2), figure 7.

Please note that the fairlead and fairlead mounting plate are supplied in the winch kit.

Use the two supplied M6 bolts, nuts, and lock washers provided with the winch as shown in figure 7. Install the lock washers and nuts on the roller fairlead side. Tighten the two M6 bolts to a recommended torque of 34 N-m (25 ft-lb).

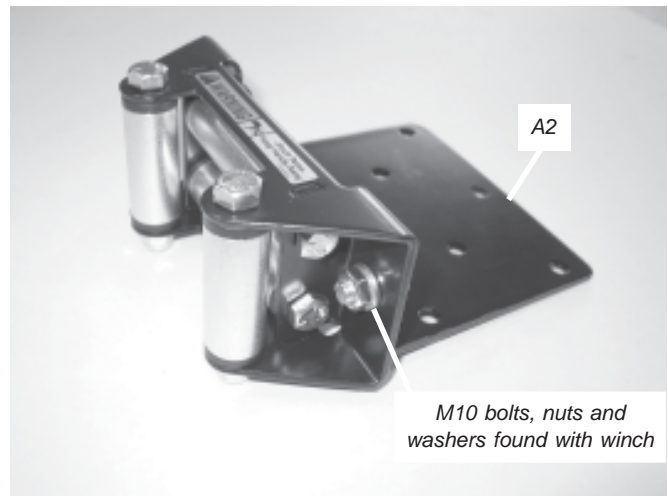

Figure 7 Attach Roller Fairlead Mounting Bracket

- Mount a Warn winch to the mounting bracket (A1) with two M8 X 20mm and two M8 X 25mm bolts and lock washers supplied with the winch kit. The winch and mounting plate must be installed on top of the fairlead mounting bracket assembled in step 7. Mount the winch so that the motor faces the right side of the vehicle, figure 8.

Note: Please refer to page 5 - figure 4 of the installation manual that came with the winch kit. It is very important to locate the mounting bolts in the correct side of the winch.

Tighten the bolts to a recommended torque of 17 N-m (12 ft-lb).

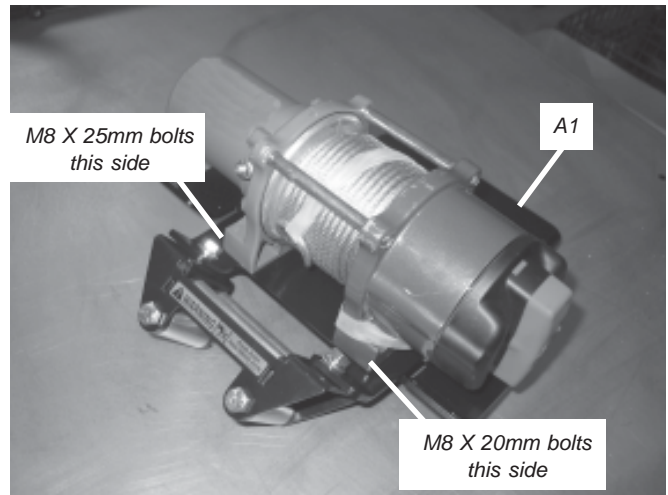

Figure 8 Initial Winch onto Mounting Bracket and Fairlead Bracket

- Place the winch, mounting plate and roller fairlead assembly into position on the front bumper, figure 9. Install two 1/4-20 x 1" x 1 3/16" U-bolts (B1), four 1/4" lock washers (B2) and four 1/4-20 nuts (B3) that were supplied in the mounting kit, figure 9. Do not tighten fasteners at this time.

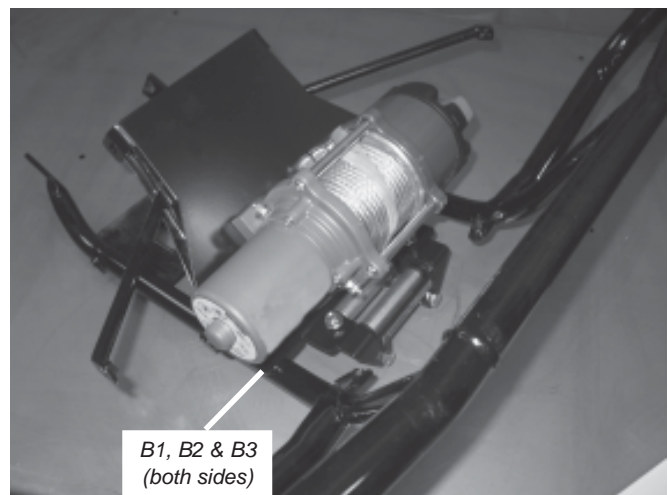

Figure 9 Place Winch, Mounting Plate and Roller Fairlead Assembly onto Front Bumper

10. Place the front bumper with attached winch assembly back onto the vehicle frame. Reinstall the four bolts that were removed in steps 4 & 5. Do not tighten at this time.
11. Install the supplied 8mm-1.25 x 25mm bolts (B4), figure 10, into the middle bumper mounting location, step 6. Do not tighten at this time.

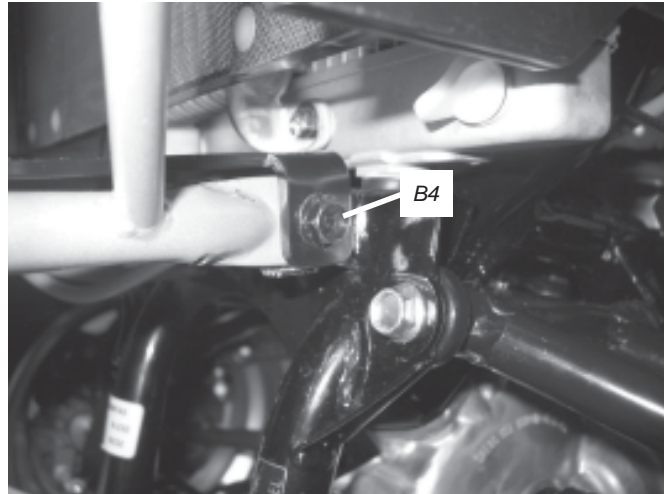

Figure 10 Install New Supplied 8mm Bolts

12. Reinstall the two 6mm bolts that were removed in step 3. Reinstall the four rivet fasteners that were removed in step 2. Do not tighten at this time.
13. Reinstall the front plastic skid plate that was removed in step 1, four side 8mm bolts and four bottom 6mm bolts. Do not tighten at this time.
14. Double check that all nuts and bolts on the winch mounting bracket, roller fairlead mounting bracket and roller fairlead are securely tightened.

Tighten all fasteners to a recommended torque of:

- 6mm bolts - 12 N-m (9 ft-lb)
- 8mm bolts - 37 N-m (27 ft-lb)
- 1/4" U-bolts - 10 N-m (7 ft-lb)

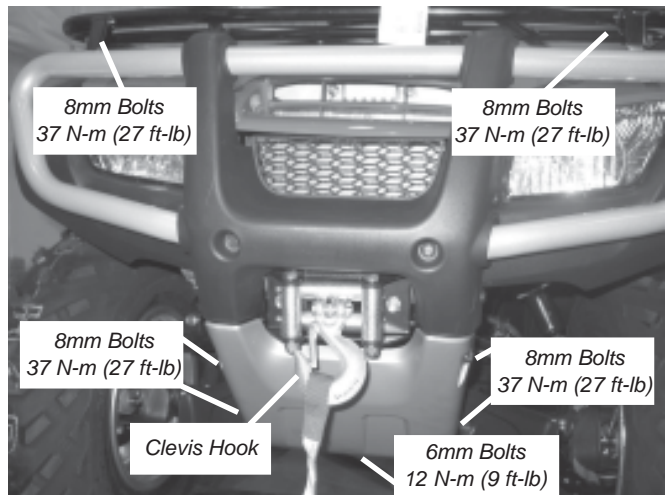

Figure 11 Completed Winch Installation on the Rubicon/Foreman 500

⚠ WARNING

Tighten all nuts and bolts securely. Failure to check all nuts and bolts prior to use can result in product failure which can lead to vehicle damage and operator injury or death.

IV. 2005 Rubicon/Foreman 500 Recommended Contactor Location

Notice

Please refer to the Installation and Specification Guide, supplied in the winch kit, for all wiring schematics and specific details on how to wire the winch to the ATV.

1. Contactor Location - Step Three in the Installation and Specification Guide:

- a. The contactor location is located in the right rear inner fender, on the right side of the rear tool box, figures 14, 15 & 16.
- b. Remove the wire harness, figure 12, from the bracket that holds the wire harness in position.
- c. Using the drill and 1/4" drill bit, remove the top of the rivet head to remove the wire harness bracket.

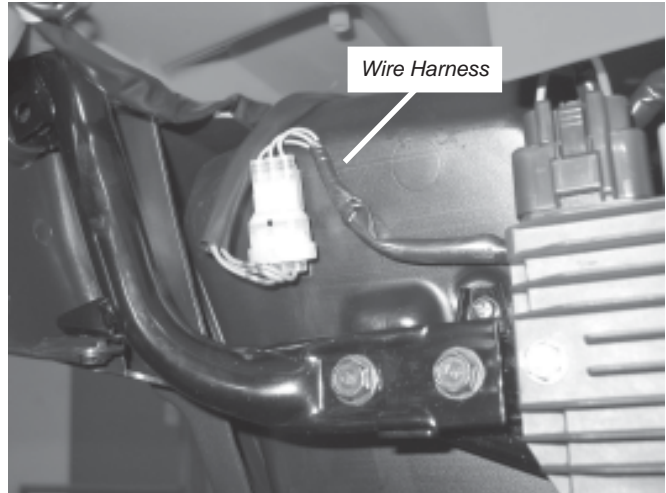

Figure 12 Remove Wire Harness from Bracket

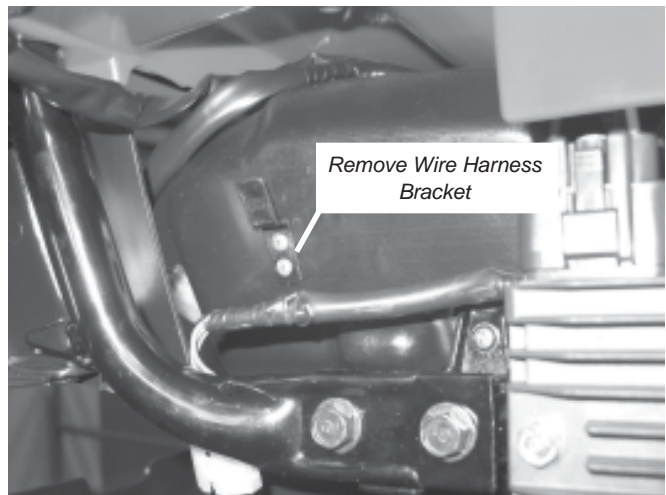

Figure 13 Remove Wire Harness Bracket

- d. Relocate the wire harness that was removed along the rear rack tube, figure 14. Use a zip-tie to secure the wire harness.

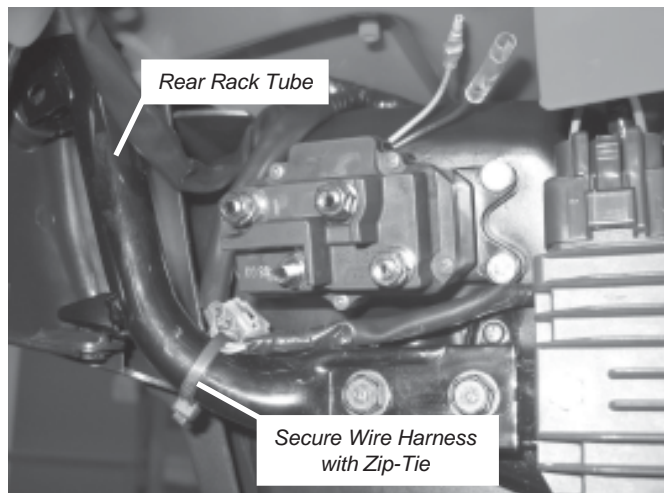

Figure 14 Contactor Location (TRX350) - Right Side of Tool Box

- e. Position the contactor with the post for the positive battery cable (red cable) in the lower left corner (leads for the handlebar switch are positioned up), figure 15 & 16. Mark and drill 1/4" holes for contactor. Secure the contactor with four M6 bolts, washers, lock-washers and nuts supplied with the winch. Tighten the nuts to a recommended torque of 7 N-m (5 ft-lb).

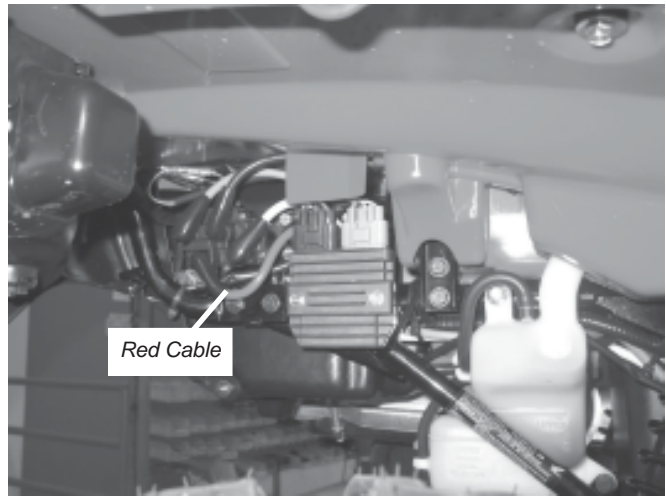

Figure 15 Contactor Location - Right Side of Tool Box

Notice

Please refer to the Installation and Specification Guide, supplied in the winch kit, for all wiring schematics and specific details on how to wire the winch to the ATV.

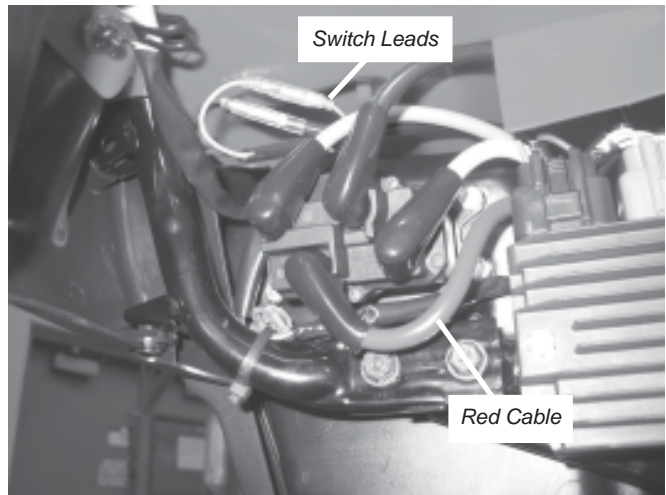

Figure 16 Contactor Location - Right Side of Tool Box

⚠ WARNING

Avoid all moving and potentially hot components of ATV when routing electrical cables. Avoid areas where the wiring could be pinched when components are reinstalled. Failure to do so can result in product failure which can lead to vehicle damage and operator injury or death.

V. Maintenance/Care

- Inspect all metal parts on the winch, winch mount, and related hardware. Replace all that appears rusted, cracked or deformed prior to use.
- Inspect all nuts and bolts on the winch, winch mount, and related hardware prior to each use. Tighten all nuts and bolts that are loose. Missing, stripped, fractured, or bent bolts or nuts need to be replaced immediately.
- Check all cables prior to use. Replace cables that are worn or frayed.
- Check all moving and rotating parts. Remove debris that may inhibit the part from moving freely.

⚠ WARNING

Failure to perform regular inspections and maintenance on the winch, winch mount, and related hardware may result in vehicle damage and operator injury or death.